

**GARAGE DU CENTRE • 1580 AVENCHES**

Philippe Meuwly SA

☎ 026 675 12 08

Equipements Handicapé ●●●●●



**CITROËN**

**Berlingo M**



**PEUGEOT**

**Rifter Standard**



**Combo Life L1**



**MODERN, HIGH-TECH AND FLEXIBLE**

A complete new driving experience guaranteed.

Developed by



# L1

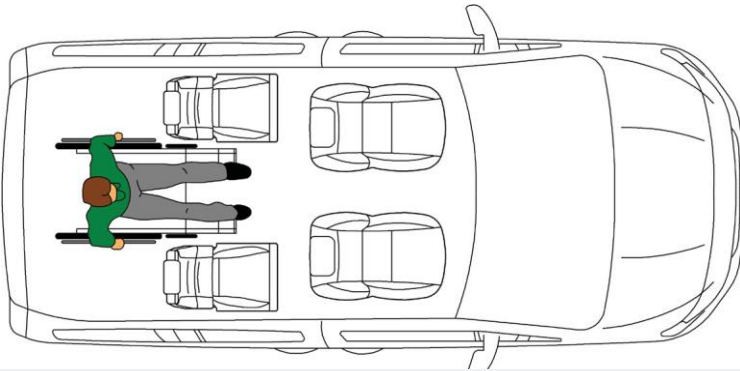
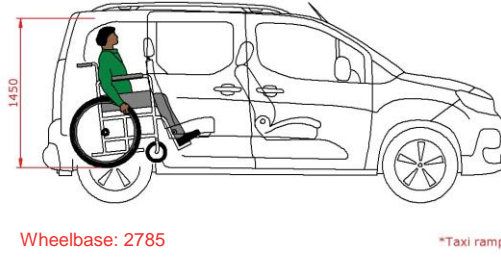
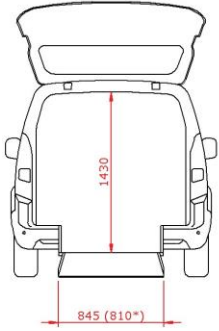
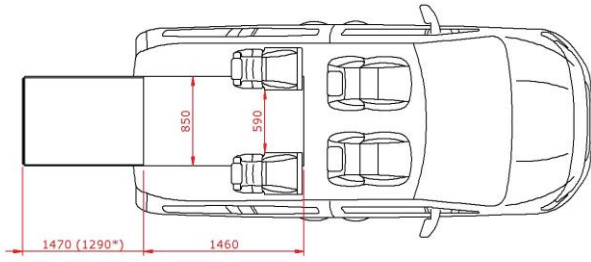

- Abgesenkter Boden von den hinteren zu den vorderen Sitzen.
- 4-Punkt-Rollstuhl-Unwin-System mit einem einstellbaren 3-Punkt-Sicherheitsgurt für den Rollstuhlfahrer.
- Neuer Kraftstofftank und modifizierte Abgasanlage Original AdBlue diesel tank.
- Doppelte klappbare leichte Rampe für freie Sicht.
- LED-Leuchten am Eingang an der Heckklappe sorgen für mehr Sichtba.
- Neue hintere Federn, um das Fahrerlebnis zu verbessern.
- Gesenkter Boden vollständig mit passender Polsterung bezogen.
- Der mittlere Teil des hinteren Stoßfängers wird auf der Look ersetzt, wodurch das ursprüngliche

### Optionnen

- Ein oder zwei (abnehmbare) Stativsitze oder erneute Installation der Originalbank in der zweiten Reihe. Taxi ramp which creates a flat loading floor.
- Original-Einparkensensoren bleiben nach dem Umbau funktionsfähig.
- Bodyguard (Rücken- und Kopfschutz für Rollstuhlfahrer).

*The intellectual content and pictures are property of Tripod Mobility.  
All pictures and specifications are based on the information available during publication.  
Although the pictures and specifications can be presumed as correct we cannot guarantee it's correctness.*

**GARAGE DU CENTRE • 1580 AVENCHES**

Philippe Meuwly SA  
☎ 026 675 12 08

Equipements Handicapé ●●●●●

